

# Adjustable Track Bar

Ford Superduty | 2005-2016

Part #: 123202 Rev. 010417

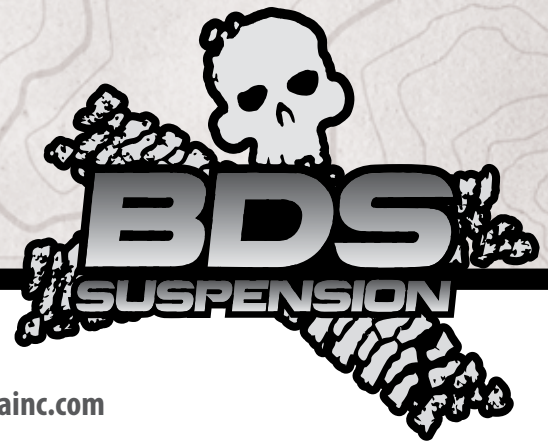

491 W. Garfield Ave., Coldwater, MI 49036 • Phone: 517-279-2135

Web/live chat: [www.bds-suspension.com](http://www.bds-suspension.com) • E-mail: [tech-bds@sporttruckusainc.com](mailto:tech-bds@sporttruckusainc.com)

Box Kit		
Part #	Qty	Description
A230	1	Track Bar Assembly
02583	1	Track Bar - frame end
02584	1	Track Bar - axle end
02738	1	Adjuster
B1068	1	Adjustable Track Bar Bag Kit
3535BK	2	Bushing
107	1	Sleeve
B56X114G8	4	Bolt
	1	Loc-Tite

## SAFETY WARNING

BDS Suspension Co. recommends this system be installed by a professional technician. In addition to these instructions, professional knowledge of disassembly/ reassembly procedures and post installation checks must be known.

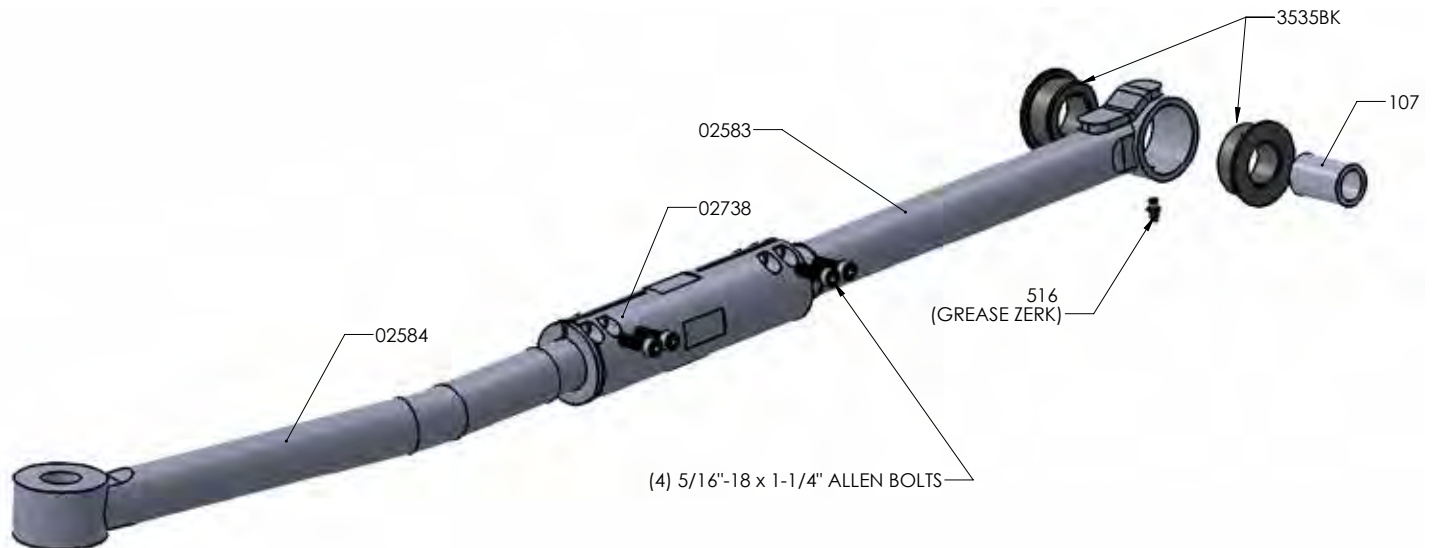

## INSTALLATION INSTRUCTIONS

1. Park vehicle on clean, flat, and level surface. Block wheels for safety.
2. Raise front of vehicle and support frame rail with jackstands. This step is necessary to dislodge the tapered track bar mount in the follow step.
3. Remove the track bar ball joint nut at the axle. (Fig 1) Thread the nut back on a couple of turns. Raise the axle a couple of inches with the jack. Place an appropriate sized pry bar between the axle mount and the track bar. (Fig 2) Lower the axle to pinch the pry bar between the track bar and axle mount. Take your hands off of the pry bar. Continue lowering the axle until the track bar unseats from the taper. Remove the nut and track bar from the ball joint. Save nut.

**FIGURE 1**

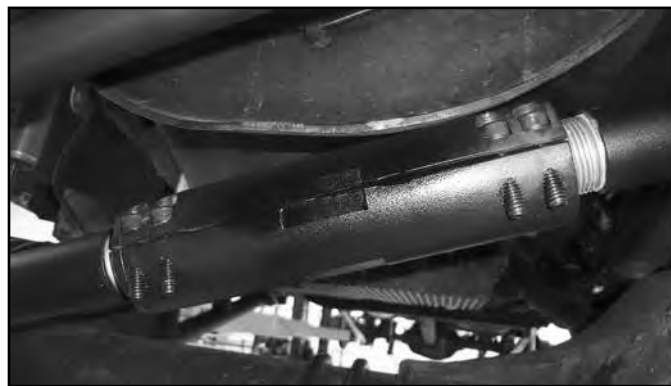

**FIGURE 2**



4. Lower the vehicle back to the ground once the track bar is disconnected from the axle.
5. Remove the stock track bar. Retain all hardware.
6. Grease and install bushings and sleeves into track bar. Thread grease zerk into track bar. Remove (4) allen bolts and apply loc-tite to threads.
7. Adjust the track bar length (eye to eye) to stock length for 0" of lift, 37-1/8" for 2" lift, 37-1/2" for 4" lift.
8. Install track bar into vehicle with the grease fitting facing down at the frame mount with factory bolt.
9. Attach the axle mount to the track bar. It may be necessary to have an assistant turn the wheel to get the mount to line up. Square the mount up to the factory joint. Attach with factory nut. Tighten to 184 ft-lbs
10. Ensure the axle is square under the vehicle. Additional adjustment of the track bar collar may be required. Do not extend past 37-5/8" eye-eye measurement, due to the maximum length of the factory drag link. Check the trackbar collar to frame crossmember for adequate clearance. A small amount of grinding on the frame crossmember lip may be required for clearance to the trackbar under compression clearance. (Fig 3)

**FIGURE 3**



11. Tighten pinch bolt collar. Tighten to 40 ft-lbs, check the turnbuckle to ensure that it will not rotate, additional tightening may be required.
12. Tighten track bar hardware at the frame to 405 ft-lbs. Grease the track bar mount at the frame.

13. An alignment is highly recommended to re-center the steering wheel. It is possible for the installer to do this by adjusting the drag link collar near the axle. Do not drive models with traction control for extended periods of time with the steering wheel off center or adverse traction control affects may arise.
14. Grease bushings and recheck hardware after 500 miles and at regularly scheduled maintenance intervals.



## **WE WANT TO SEE YOUR RIDE!**

Grab photos of your BDS-equipped truck in action and send them in for a chance to be featured. Send it in to our Bad Ass Rides customer gallery at [bds-suspension.com/bar](http://bds-suspension.com/bar) and post them on the BDS Fan Page on Facebook at [facebook.com/BDSSuspensions](https://facebook.com/BDSSuspensions). Don't forget about your BDS swag! BDS offers t-shirts, hoodies, decals and more available on the BDS website or through your local BDS distributor.

---

## **TIME TO HAVE SOME FUN**

### **Thank you for choosing BDS Suspension.**

For questions, technical support and warranty issues relating to this BDS Suspension product, please contact your distributor/installer before contacting BDS Suspension directly.